



Annandale

PRE CAST
CONCRETE LINTELS
SILLS & COPINGS

THE EXPERTS IN THE MANUFACTURE AND SUPPLY OF **PRE-CAST CONCRETE PRODUCTS**

PRESTRESSED CONCRETE LINTELS

Annandale prestressed lintels are produced in a comprehensive range of shapes, sizes and lengths; combined with galvanised or stainless steel angle lintels, the standard range satisfies most loadbearing situations. If required, special units can be manufactured to order.

Authority/Materials

- Concrete lintels from Annandale Structural Concrete (Annandale) are manufactured to comply with BS 8110: Part 1: 1997.
- OPC is in accordance with BS 12:1989, and aggregates used are in accordance with BS 882: 1983.
- Reinforcement is 5mm indented steel wire to BS 5896: 1980, having a minimum tensile stress of 1670N/mm².

Technical Details

- All Annandale lintels must be installed in accordance with current Building Regulations and good working practice.
- Annandale lintels offer a minimum of 1/2 hour fire resistance in accordance with Table 4.3 of BS 8110: Part 2. Higher ratings can be achieved by the addition of suitable site finishes.
- Annandale's quality-controlled dense concrete mix results in a low water absorption, therefore lintels can be used underground, provided that the ends of the units have a minimum 45mm cover to the reinforcing wires.

Full design calculations can be provided for planning submissions

Installation

All Annandale lintels are marked "TOP" and this surface should be laid uppermost. It is very important that lintels are installed at the correct orientation or their design performance may be compromised. If in doubt, or if the TOP mark cannot be seen, the lintel should be built-in so that the stressing wires visible on the end faces are in the lower section of the unit. (See Diagram A)

Lintels should be installed with a minimum end bearing of 150mm at each end, and should be levelled and fully bedded on bricklaying mortar.

Masonry may overhang the supporting lintel by a maximum of 25mm. Wall ties should be used in accordance with BS 5628 and current Building Regulations.

A flexible damp proof course (cavity tray) must be installed to all external wall lintels. This should extend a minimum of 100mm past the ends of the lintel and should finish flush with the front edge of the external lintel. Weepholes should be provided at 450mm centres. (See paragraph on insulation)

The gap between the window/door head and the soffit of the lintel should be sealed with a suitable flexible compound.

Shock loads from concrete floor units should be avoided. It is advisable to provide temporary support during the laying of floor units, a lintel depth of 145mm is recommended to allow for impact loads.

When storing lintels on site, they should be stacked flat on a firm level surface with "TOP" uppermost. Timber bearers must be positioned near the ends of the lintels and vertically in line.

Insulation

Provision should be made to limit the thermal bridging which occurs around windows, doors and other wall openings. This is necessary to avoid excessive heat loss and the possibility of localised condensation. (See diagrams)

Annandale provide a THERMA-CLOSE insulation system combined with an integral damp proof membrane, suitable for our range of prestressed concrete lintels, which complies with Building Regulations requirements.

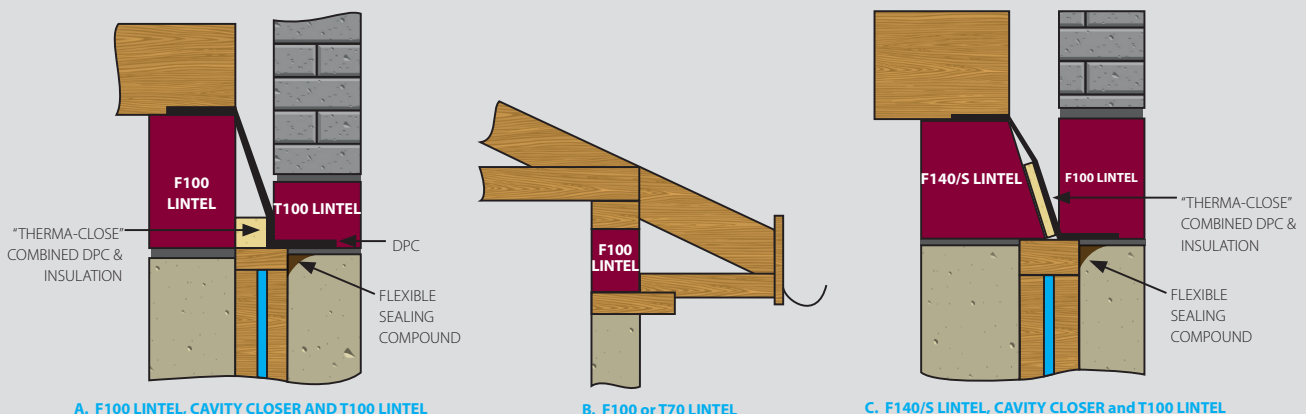

A. F100 LINTEL, CAVITY CLOSER AND T100 LINTEL

B. F100 or T70 LINTEL

C. F140/S LINTEL, CAVITY CLOSER and T100 LINTEL

LOAD / SPAN TABLES FOR CONCRETE LINTELS

Lintel Size		Load / Span Table- Maximum Service UDL in kN/m* (No composite action with masonry over) CLEAR SPAN - mm											
TYPE	W x D (mm)	900	1200	1500	1800	2100	2400	2700	3000	3300	3600	3900	4200
T100	100 x 70	8.50	4.87	3.16	2.21								
T70	70 x 100	11.77	6.80	4.42	3.10	2.30							
F100	100 x 145	40.44	28.80	19.03	13.50	10.07	7.80	6.21	5.07	4.22	3.56	3.05	
F140	140 x 145	54.93	39.00	25.75	18.26	13.62	10.55	8.41	6.86	5.70	4.82	4.12	3.57
F140/S	100/140 x 145	43.86	35.24	23.26	16.50	12.30	9.53	7.60	6.20	5.15	4.35	3.72	

* Live Load not exceeding 50% of Total Load

SUMMARY OF LINTEL PROPERTIES

Lintel Size		Average Weight	MR	MuR	Vco*
TYPE	W x D (mm)	(kg/m)	(kN-m)	(kN-m)	(kN)
T100	100 x 70	16	0.965	1.394	12.76
T70	70 x 100	16	1.378	1.992	13.07
F100	100 x 145	34	6.09	9.144	27.30
F140	140 x 145	47	8.34	12.36	37.08
F140/S	100/140 x 145	41	7.717	11.56	32.90

*Assumes minimum 100mm bearings. Normal bearing 150mm.

COMPOSIT ACTION OF 100W x 70D PRESTRESSED LINTEL WITH MASONRY OVER:-

A. Brickwork - minimum 20N/mm² bricks Maximum Service UDL in kN/m* Clear Span - mm

No. of Courses	Overall Depth inc. Lintel	900	1200	1500	1800	2100	2400	2700	3000
2	220	8.50	4.87	3.16	2.21	1.39			
3	295	12.42	7.35	4.85	3.44	2.56	1.99		
4	370	20.29	12.20	8.06	6.71	4.26	3.30	2.63	
5	446	20.29	15.22	12.07	8.56	6.38	4.94	3.94	3.21
6	520	20.29	15.22	12.18	10.15	8.70	6.92	5.50	4.50

* Live Load not exceeding 50% of Total Load. Note: Lintels to be propped at 1.2m centres until masonry has cured.

B. Blockwork - 7N/mm² Maximum Service UDL in kN/m* Clear Span - mm

No. of Courses	Overall Depth inc. Lintel	900	1200	1500	1800	2100	2400	2700	3000
1	295	13.38	7.92	5.23	3.71	2.76	2.14		
2	520	20.29	15.22	12.18	10.15	8.70	7.44	6.94	4.84

* Live Load not exceeding 50% of Total Load. Note: Lintels to be propped at 1.2m centres until masonry has cured.

PRE CAST SILL DIMENSIONS

SILL

Without ears, can be cut on site to suit an opening.
Lengths of: 1000mm 1200mm 1500mm 1800mm 2000mm

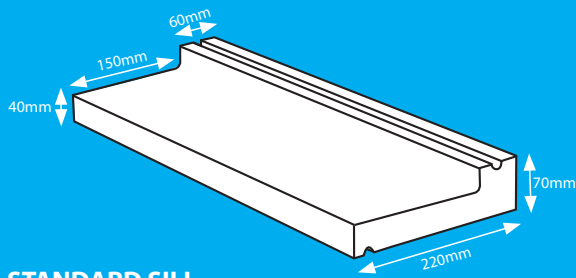

STANDARD SILL

Without ears, can be cut on site to suit an opening.
Lengths of: 1300mm 2000mm

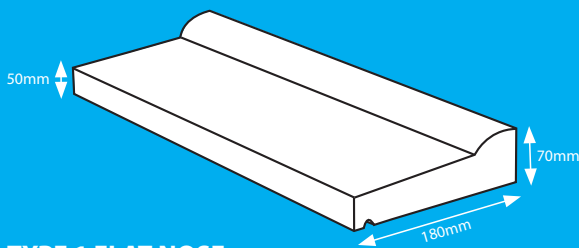

TYPE 1 FLAT NOSE

With or without ears. 2200mm max length.

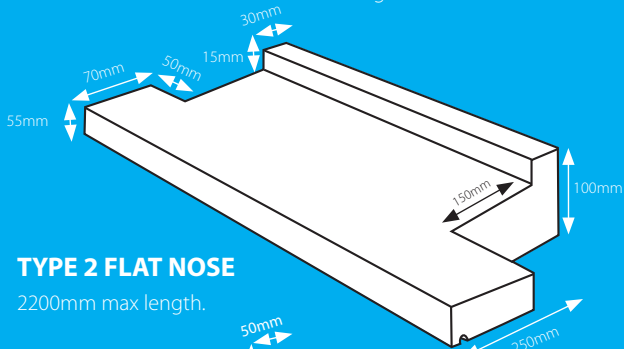

TYPE 2 FLAT NOSE

2200mm max length.

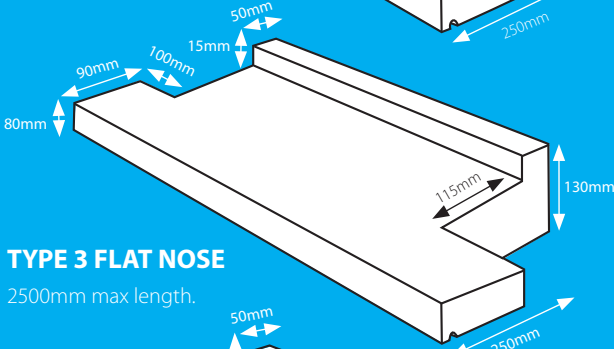

TYPE 3 FLAT NOSE

2500mm max length.

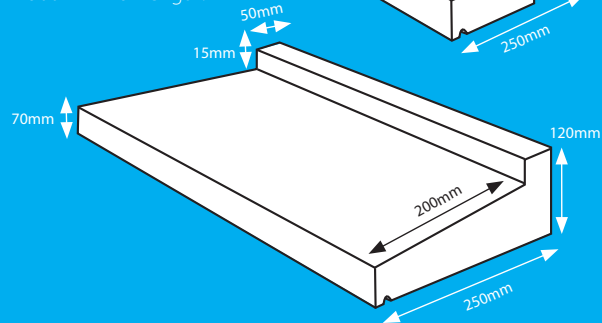

TYPE 1 BULL NOSE

With or without ears. 2800mm max length.

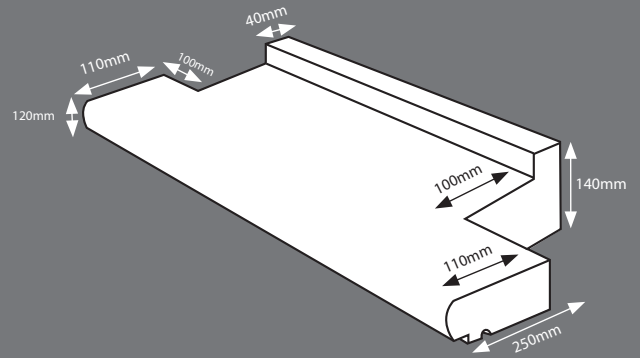

TYPE 2 BULL NOSE

With or without ears. 2700mm max length.

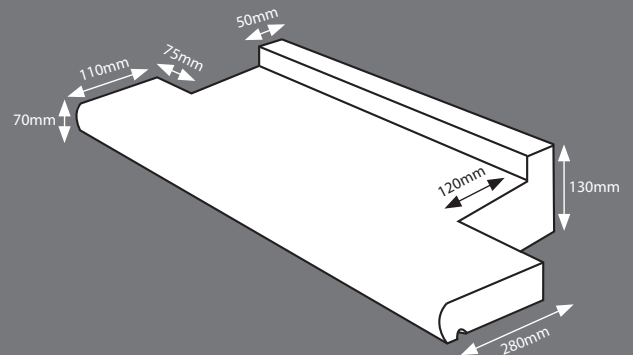

TYPE 3 BULL NOSE

With or without ears. 2500mm max length.

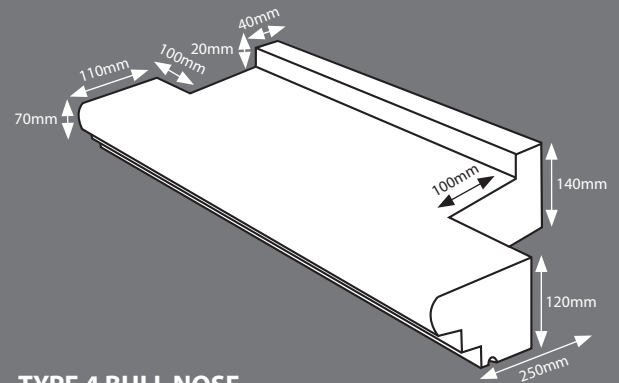

TYPE 4 BULL NOSE

With or without ears. 2800mm max length.

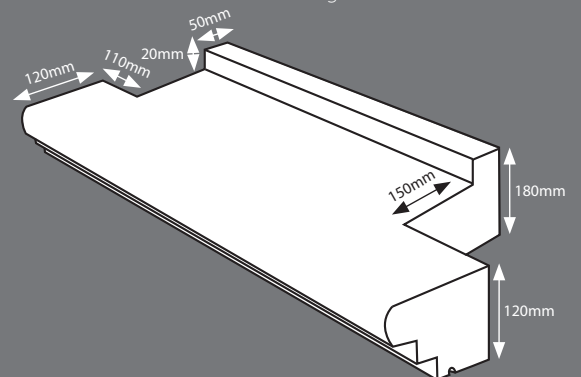

PRE CAST COPING DIMENSIONS

LARGE COPING

Best suited for a 300mm wall.

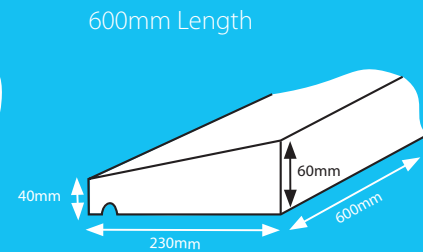
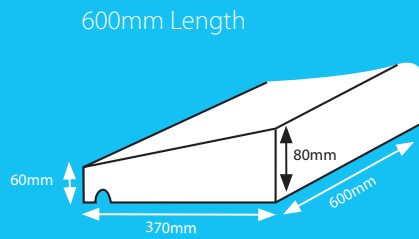
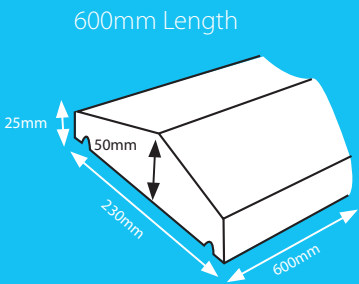
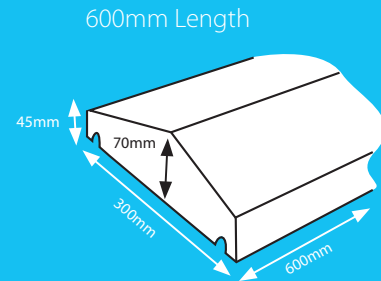
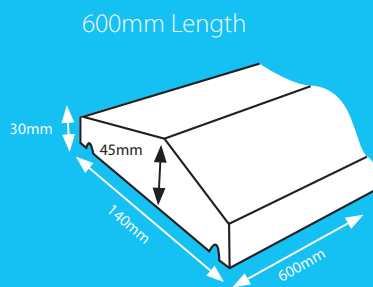
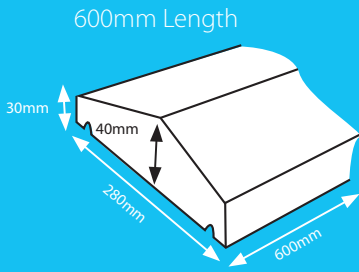

CONCRETE BOLLARDS

PILLAR CAPS

450mm²

525mm²

600mm²

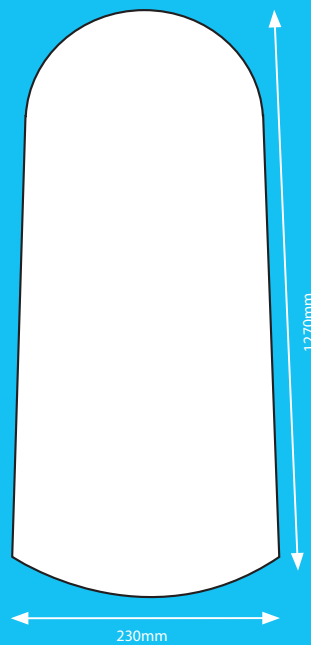
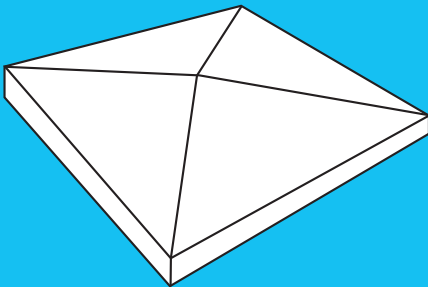

If required, special units can be manufactured to order.

WE ARE THE EXPERTS IN THE MANUFACTURE AND SUPPLY OF PRE-CAST CONCRETE PRODUCTS.

PRE-CAST CONCRETE PRODUCTS

Where We Are



ANNANDALE Ltd.

Rue des Marais, Vale, Guernsey, C.I., GY6 8BA

factory: (01481) 253088 m: 07781 156004

E: timg@asc.gg www.annandale.gg